

Screwed Process Connection, Diaphragm Seals Model 990.38, Welded Design, Economic Design

WIKA Data Sheet DS 99.05

Applications

- Standard applications in process industry
- Suitable for corrosive, contaminated or heterogeneous pressure media

Special Features

- Design with internal diaphragm, upper and lower housing welded
- No sealing
- Excellent cost-performance ratio



Diaphragm Seal, Economic Design Model 990.38 with
Pressure Gauge Model 232.50 NS 100

Description

Pressure rating

PN 90 up to 150 °C,
at higher temperatures see table page 2

Suitable pressure ranges

0 ... 0.6 bar to 0 ... 90 bar

Upper housing (instrument connection)

Material stainless steel 316 L, G ½ female

Diaphragm

Material stainless steel 316 L, welded with upper body
Effective diameter d_M of diaphragm $d_M = 50$ mm

Lower housing (process connection)

Material stainless steel 316 L, G ½ B male,
optional ½ NPT male

Possible combinations

Bourdon tube pressure gauges

Recommended possibility of combination diaphragm seal Model 990.38 with a pressure gauge with bourdon tube model 232.50/233.50.100

if the following application conditions are taken into account:

- Pressure gauge directly combined with diaphragm seal
- Temperature range
 - process: -10 ... +150 °C
 - ambient -10 ... +40 °C
- Fill fluid KN 2 Silicon oil

In case of differing working conditions ask your customer support at WIKA.

Maximum areas of application

	Temperature			
	50 °C	100 °C	150 °C	200 °C
Pressure maximum in bar	110	100	90	82

Example for mounting of a diaphragm seal model 990.38 directly connected with pressure gauge

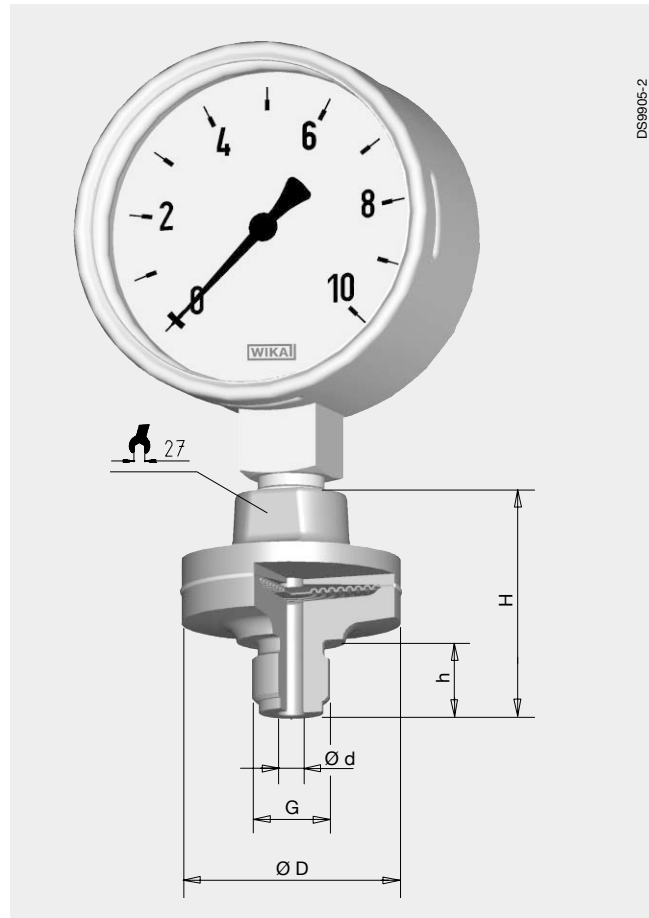

Dimensions in mm

Process connection G	Dimensions in mm				Weight in kg
	D	d	H	h	
G ½ B	59	7	60.5	20	0.48
½ NPT	59	7	59.5	19	0.48

Ordering information

Model / Process connection / Fill fluid / Pressure gauge model / Pressure range / Process conditions

Modifications may take place and materials specified may be replaced by others without prior notice. Specifications and dimensions given in this leaflet represent the state of engineering at the time of printing.

